



ASSEMBLING INSTRUCTIONS

TROLLEY

with brackets for
extraction arm



FOR A BETTER WORKBENCH ENVIRONMENT



FILTRONIC AB
Hissgatan 2, Box 2284, 531 02 LIDKÖPING
Tel: +46 510 208 10, Fax: +46 510 201 40
e-mail: office@filtronic.se
www.filtronic.se

Version 5
11.02.2008



Table of content

1.	Introduction	2
2.	Content	2
3.	Assembling	3-6
4.	Technical data	7
5.	Article number	7
6.	Warranty	7

1. Introduction

Mobile unit with arm rack for mounting on filter unit MG75 or MG95 from Filtronic.

2. Content

Extraction arms and filter unit are bought separately and are not included in this packaging.

1. Mobile unit
2. Rubber hose, 2 pcs
3. Screw MRT-TT M4x10, 4 pcs
4. Screw M4x20, 6 pcs
5. Nut M4, 6 pcs
6. Arm rack, 2 pcs
7. Mounting plate, 2 pcs
8. Plastic knob, 4 pcs

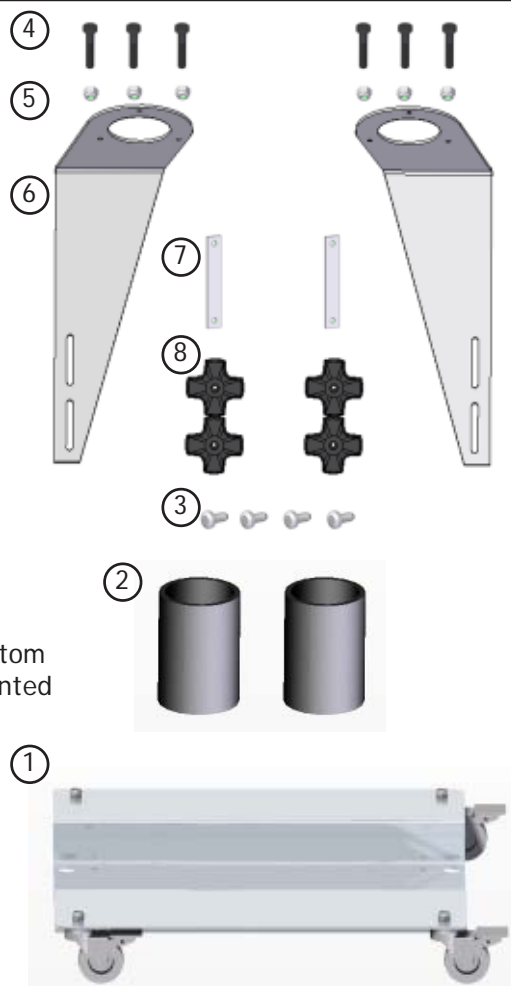

NOTE! If extraction arm is not bought together with the mobile unit, a quick-connection is mounted at the bottom of the foot pipe. This needs to be dismantled with a drill machine, not enclosed in this packaging.

4. Technical data

Width:	450 mm (17,7 inch)
Depth:	450 mm (17,7 inch)
Height, with filter unit mounted:	750 mm (29,5 inch)

5. Article number

Mobile unit with arm rack to MG75 and MG95	950-3202-ESD
--	--------------

6. Warranty

General conditions according to ORGALIME S 2000.

Filtronic AB guarantees the product for manufacturing failures for a time period of one (1) year on filter units and accessories, consumptions not enclosed. The time is measured from date of invoice.

Only use genuine Filtronic AB consumables and spare parts in order to ensure reliable function and to maintain the unit's warranty. Repairs must be performed by personnel trained by Filtronic AB.

The information given is not binding and does not free the user from his or her responsibility to check the equipment before using it.

Filtronic AB reserves the right to introduce technical changes in the course of product development.

Always contact the supplier before return a product. The invoice has to be shown at the time of the complaint.

9. When assembling two extraction arms on filter unit MG95, repeat from point 6, side 5.

When assembling on filter unit MG75, go to point 10.

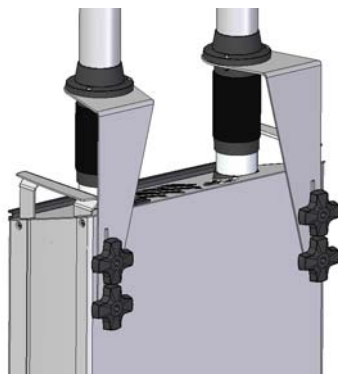

10. Put back filter and front. The assembling is ready.

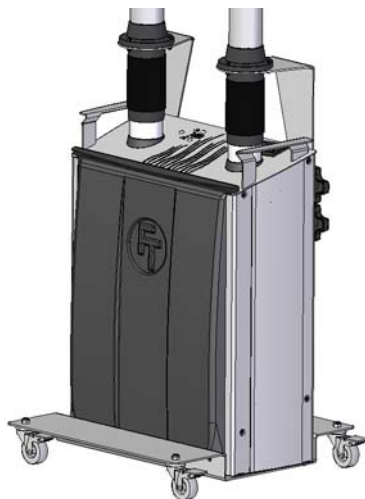

3. Assembling

Mobile unit:

1. Put the filter unit on a table, 15 cm outside the table edge.
2. Assemble the mobile unit (1) on the filter unit with four screws (3).



3. The assembling of the mobile unit is ready.



Assembling of arm rack:

1. Pull the front of the unit (9) straight up. Remove it from the unit.
2. Pull the hose connections (11) straight up, app. 20 mm, until the text on the hoses is visible.
3. Take away the filter (2).
4. Make sure that quick-connections are mounted on the connection pipes (11).



5. Mount a rubber hose (2) on each quick-connection.

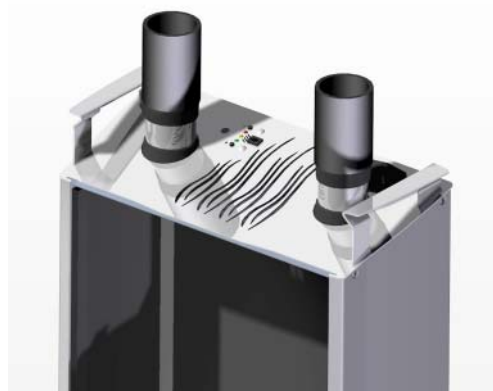

6. If the extraction arm is not bought together with the mobile unit and already is mounted on the filter unit, the quick-connection at the bottom of the foot pipe needs to be dismantled. Drill out the pop rivets with a 4 mm drill. Dismount possible table bracket.

7. Assembly the foot part of the extraction arm and the arm rack (6) with:
 - 3 pcs screw, M4X20 (4),
 - 3 pcs nut, M4 (5).



8. Mount the arm rack on the filter unit with one mounting plate (7) and two plastic knobs (8).

